

INSTALLATION INSTRUCTIONS

PRODUCT: **UFO-X DIMMABLE HIGH BAYS**
 PRODUCT CODES: **UFOX100-40, UFOX100-65, UFOX150-40, UFOX150-65, UFOX200-40, UFOX200-65**

BOX CONTENTS -

UFO-X Dimmable High Bay

SPECIFICATION

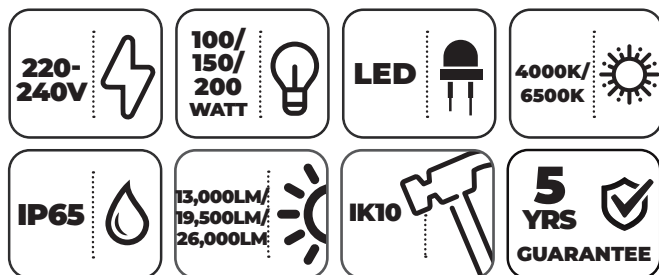

Dimensions:	Ø: 252 x H: 126.5mm
Material:	Die-cast aluminium body & tempered glass lens
Working Temperature:	-30° to 45°C
Included:	Hanging / Mounting Bracket

MAXIMUM FITTINGS PER CIRCUIT

Automatic Circuit Breaker Type	B6	B10	B13	B16	B20	C10	C13	C16	C20
Rated Current	6A	10A	13A	16A	20A	10A	13A	16A	20A
Cable (mm)	1.5	1.5	1.5	1.5	2.5	1.5	1.5	1.5	2.5
UFOX100-40/65	3	5	7	8	11	9	11	14	18
UFOX150-40/65	3	5	7	8	10	9	11	14	18
UFOX200-40/65	1	3	5	6	7	6	8	10	13

SAFETY WARNING



- The installation should be carried out by a qualified electrician in compliance with the current edition of the IEE Wiring Regulations.
- Prior to installation, carry out the necessary risk assessment considering the people who could be at risk, the level of risk and the precautions required to control the risk
- Ensure that the circuit supply is isolated either by the circuit supply fuse being removed or the applicable circuit breaker being turned off before installation or any maintenance.
- Check the total load on the circuit ensuring the luminaire does not exceed the rating of the circuit cable, fuse or circuit breaker.
- Long-term use and voltage fluctuations can reduce the life span of the fitting.
- If the fitting incorporates control gear, ensure careful sizing to avoid instances of nuisance tripping of the protective device used in the installation.
- Follow the provided installation instructions, using the fixings supplied or recommended.
- Keep out of reach of children.

INSTALLATION INSTRUCTIONS

1. DRILL A HOLE IN THE CEILING & INSTALL A HOOK.
2. HANG THE FITTING ON TO THE HOOK USING THE EYELET PROVIDED, WHICH SHOULD BE SCREWED INTO TOP OF HOUSING.
3. USING A SUITABLY RATED CONNECTOR OR JUNCTION BOX CONNECT THE AC CABLES:
BROWN- LIVE
BLUE - NEUTRAL
YELLOW/GREEN - EARTH
4. IF REQUIRED, USING A SUITABLY RATED CONNECTOR OR JUNCTION BOX CONNECT THE 1-10V DIMMABLE CABLES:
BLUE - DIM
WHITE - DIM
[IF NOT REQUIRED DO NOT ALLOW TO TOUCH]

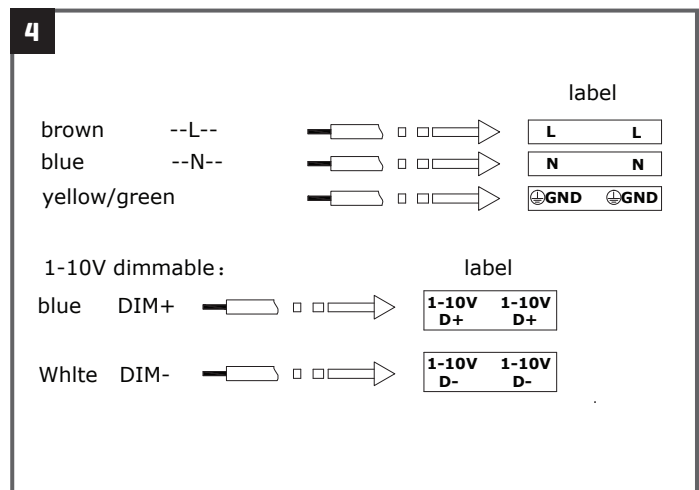
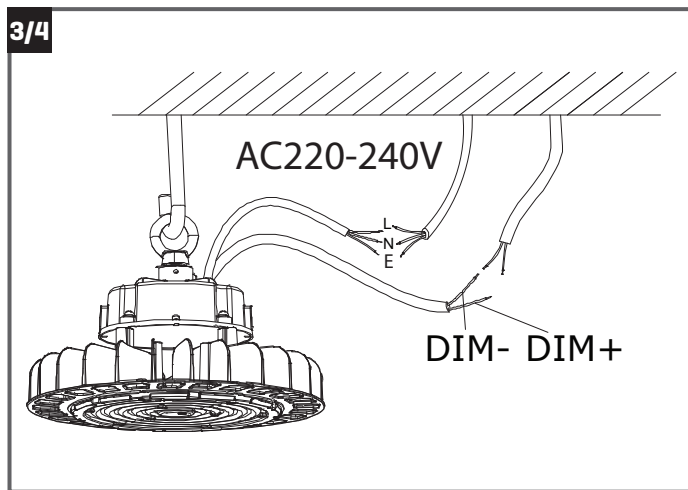
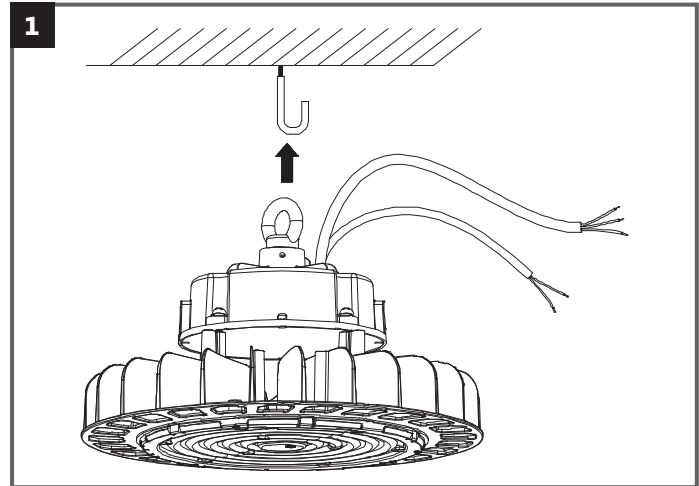

GUARANTEE

This product is guaranteed for a period of 5 years from the date of purchase. The guarantee is invalid in the case of improper use, tampering, removal of the Q.C. date label, installation in an improper working environment or installation not according to the current edition of the I.E.E. Wiring Regulations [BS7671].

The guarantee is also invalidated if the luminaire has been insulation tested. Should this product fail during the guarantee period it will be replaced free of charge, subject to correct installation and return of the faulty unit. We do not accept responsibility for any installation costs associated with the replacement of this product. Your statutory rights are not affected. We reserve the right to alter specifications without prior notice.

MAINTENANCE

- This fitting will require routine cleaning if used in adverse (dust, paint, welding, oils etc) environments. Do not use solvents, aggressive detergents or abrasives.
- When this fitting comes to the end of its life or you choose to replace it, please do not dispose of it with your general waste. Please recycle where the facilities exist, check with your local authority for suitable options.